

Instructions



Harrier+TM Chemical Injection Controller

3A3098B
EN

For controlling and monitoring an automated chemical injection system. Not approved for outdoor use or use in explosive atmospheres or hazardous locations.

See page 3 for approvals and model information.



Important Safety Instructions

Read all warnings and instructions in this manual.
Save these instructions.

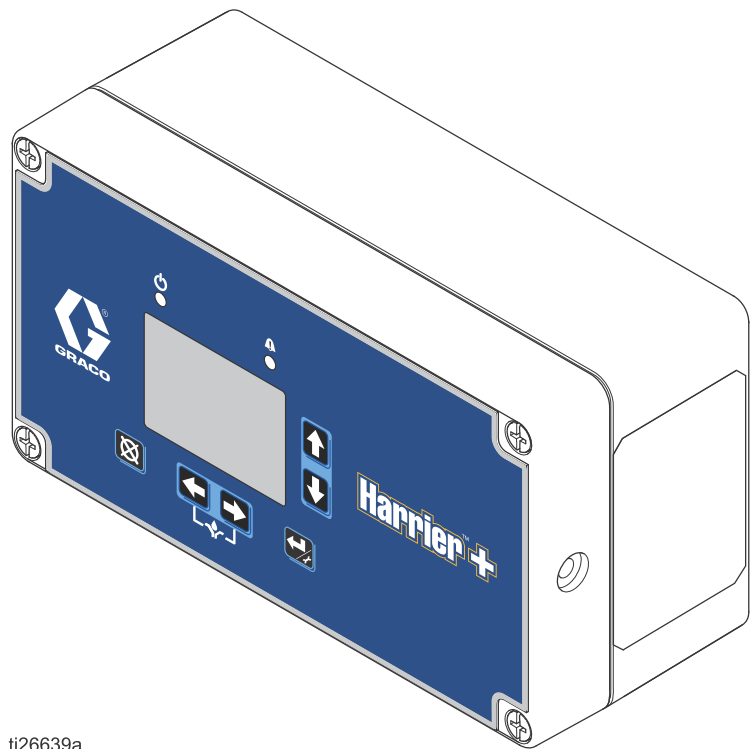

ti26639a



Table of Contents

Models	3	Appendix A: Modbus Interface	42
Warnings	4	PC Interface	42
Component Identification	5	PLC Interface	42
Keypad, Display, and Icons	5	Variable Maps	42
Installation	7	Technical Data	47
Installing the Injection Controller	7	Graco Standard Warranty	48
Grounding	7	Graco Information	48
Typical 12 VDC Installation	8		
Typical 120 VAC Installation	9		
Typical 240 VAC Installation	10		
Theory of Operation	11		
Flow Control Summary	11		
Cycle Control Summary	11		
Time Control Summary	11		
Pump Calibration	11		
Controller Setup	12		
Configuration Screen	12		
Pump Setup Screen (Flow Mode)	12		
Pump Setup Screen (Time Mode)	13		
Pump Setup Screen (Cycle Mode)	14		
Alarms Setup Screen	14		
PIN Code Setup Screen	15		
PIN Code Entry Screen	16		
Network Setup Screen	16		
Advanced Setup Screen	18		
Run Screens	19		
Screen Identification	19		
Alarms and Signal Events	20		
Harrier+ Web Portal	21		
Creating a New Account	22		
Logging In to the Web Portal	24		
Pumps List Screen	26		
Pumps Detail Screen (Pump Connected)	27		
Pumps Detail Screen (Pump Disconnected)	31		
Groups List Screen	32		
Groups Detail Screen	33		
Invitation to Join a Group	35		
Settings Screen	36		
Help Screen	37		
Troubleshooting	38		
Program Settings	40		
Dimensions and Mounting Hole Layout	41		

Approvals



* See pages 9 and 10 for installation requirements.



Intertek
3151640
Certified to CAN/CSA C22.2 No. 14
Conforms to
UL 508

Related Manuals



Manual No.	Description
3A3100	Wolverine Premium Chemical Injection System
334513	Wolverine Chemical Injection Pump

Models

Part No.	Description
B32022	Harrier+ Controller, DC Power, CDMA
B32148	Harrier+ Controller, DC Power, GSM
B32189	Harrier+ Controller, AC Power, CDMA
B32150	Harrier+ Controller, AC Power, GSM
B32155	Harrier+ Controller, DC Power, SCADA
B32156	Harrier+ Controller, AC Power, SCADA

Warnings

The following warnings are for the setup, use, grounding, maintenance, and repair of this equipment. The exclamation point symbol alerts you to a general warning and the hazard symbols refer to Procedure-specific risks. When these symbols appear in the body of this manual or on warning labels, refer back to these Warnings. Product-specific hazard symbols and warnings not covered in this section may appear throughout the body of this manual where applicable.

 WARNING	
	<p>ELECTRIC SHOCK HAZARD</p> <p>This equipment must be grounded. Improper grounding, setup, or usage of the system can cause electric shock.</p> <ul style="list-style-type: none"> • Turn off and disconnect power at main switch before disconnecting any cables and before servicing or installing equipment. • Connect only to grounded power source. • All electrical wiring must be done by a qualified electrician and comply with all local codes and regulations.
	<p>EQUIPMENT MISUSE HAZARD</p> <p>Misuse can cause death or serious injury.</p> <ul style="list-style-type: none"> • Do not operate the unit when fatigued or under the influence of drugs or alcohol. • Do not exceed the maximum working pressure or temperature rating of the lowest rated system component. See Technical Data in all equipment manuals. • Use fluids and solvents that are compatible with equipment wetted parts. See Technical Data in all equipment manuals. Read fluid and solvent manufacturer's warnings. For complete information about your material, request Safety Data Sheet (SDS) from distributor or retailer. • Turn off all equipment and follow the Pressure Relief Procedure when equipment is not in use. • Check equipment regularly. Repair or replace worn or damaged parts immediately with genuine manufacturer's replacement parts only. • Do not alter or modify equipment. Alterations or modifications may void agency approvals and create safety hazards. • Make sure all equipment is rated and approved for the environment in which you are using it. • Use equipment only for its intended purpose. Call your distributor for information. • Route hoses and cables away from traffic areas, sharp edges, moving parts, and hot surfaces. • Keep children and animals away from work area. • Comply with all applicable safety regulations.

Component Identification

Keypad, Display, and Icons

NOTICE

To prevent damage to soft key buttons, do not press the buttons with sharp objects such as pens, plastic cards, or fingernails.

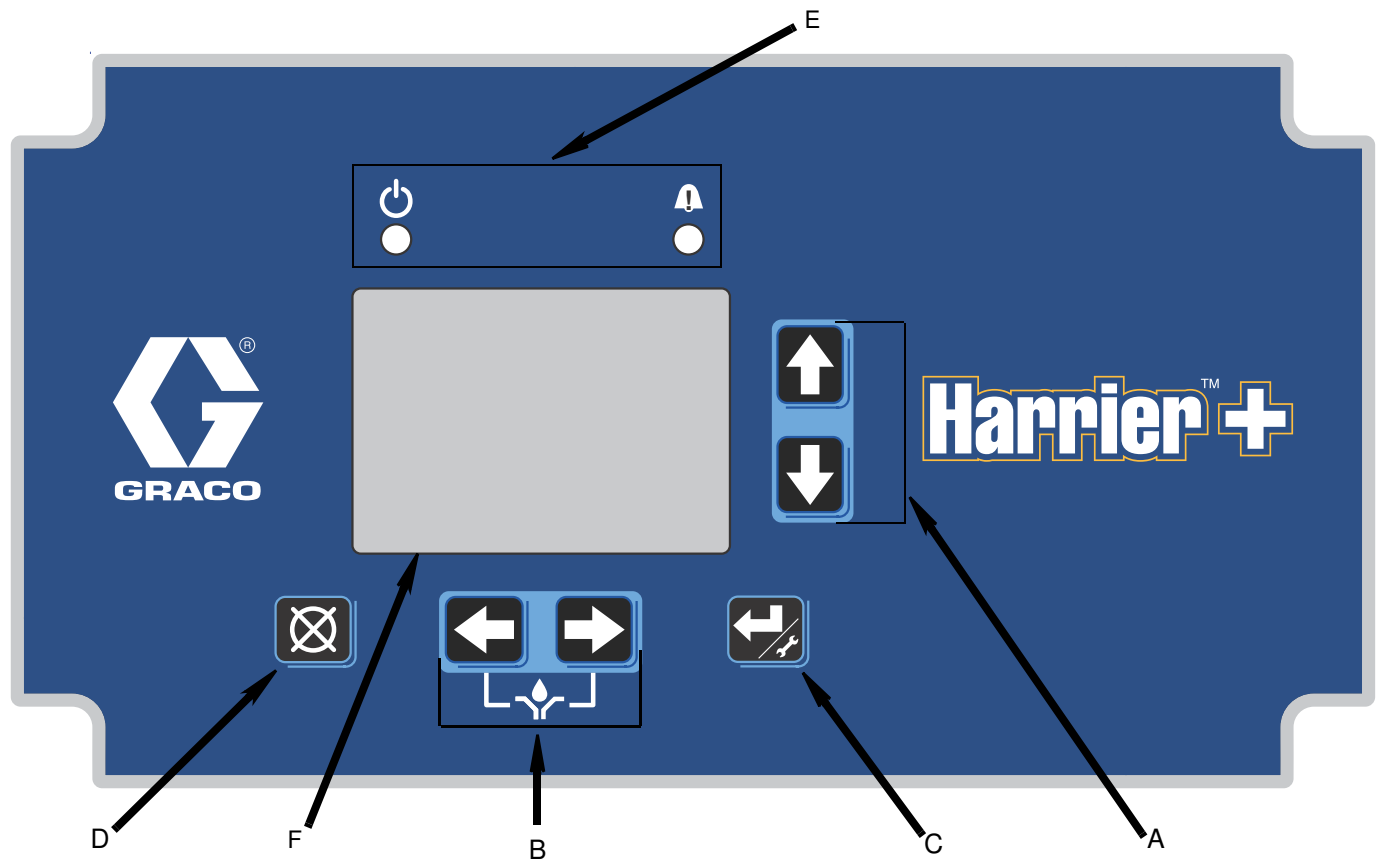

FIG. 1 Harrier+ Keypad and Display

Run Mode Functions

Direction Arrows

- A Up and Down Arrow Keys:
- Navigate screen menus.
 - Increase or decrease values in numeric fields.
- B Left and Right Arrow Keys:
- Navigate screen menus.
 - Press both keys simultaneously to manually start a pump cycle or prime the pump.
 - Moves one digit to the left or right to edit numeric fields.











Keypad Icons

NOTE: Keypad icons are described on page 6.

- C Enter Key: Press and hold for 3 seconds to access the Configuration screen (see FIG. 6, page 12). Also is used to save changes to setup fields (see **Setup Screens**, starting on page 12).
- D Reset Key: Resets unit to the pump run screen. Also is used to reset an alarm condition.
- E Function LED: See page 6 for a description of these icons.
- F Display

Icons

The following icons are used throughout this instruction manual and on the Controller's Run and Setup Screens. Refer to this table if you are unsure of an Icon's meaning.

-  **Power On indicator.** When power is supplied to the controller, Green LED illuminates under Function Icon located above display screen.
-  **Pump On indicator.** Displayed on right side of Pump Run screens during the Pump On cycle.
-  **Pump Off indicator.** Displayed on right side of Run screens during the Pump Off cycle.
-  **Setup Mode active.** Displayed on the upper right corner of the Configuration screen.
-  **Time Mode active.** Displayed on top right side of screen when the Time Run screen is displayed.
-  **Cycle count Mode active.** Displayed on top right side of display screen when the Cycle Run screen is displayed.
-  **Alarm active.** Red LED illuminates under the Function LED located above the display screen when an alarm event occurs.
-  **Flow Mode active.** Displayed on the top right side of the display screen when the Flow Run screen is displayed.
-  **Signal Strength.** Displayed on the Network screen when Cell is selected and cell signal detected.
-  **DC Voltage.** Displayed next to the battery voltage on the left side of Run screens. (Applies to DC models only.)
-  **Pressure.** Displayed next to the pressure reading on the left side of Run screens.

Installation

Installing the Injection Controller



AUTOMATIC SYSTEM ACTIVATION HAZARD

Unexpected activation of the system could result in serious injury, including skin injection and amputation.

This device has an automatic timer that activates the chemical injection system when power is connected or when exiting the programming function. The device can also be activated remotely from internet portals. Before you install or remove the controller from the system, disconnect and isolate all power supplies, and relieve all pressure.

1. Select a flat surface to install the Injection Controller. Refer to **Dimensions and Mounting Hole Layout** on page 41.

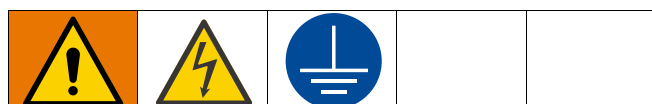

All electrical wiring must be done by a qualified electrician and comply with all local codes and regulations.

Opening the controller to remove the screws that attach the mounting plate to the controller may expose the assembler to live voltage. Do not remove the mounting plate.

2. Align the mounting surface with predrilled holes on mounting plate. Use mounting studs (provided) with two 1/4-20 nuts (not provided).

NOTICE

Use only designated mounting plates and holes in controller enclosure. Do not drill additional mounting holes as it can cause circuit board damage.

Grounding



The equipment must be grounded to reduce the risk of static sparking and electric shock. Electric or static sparking can cause fumes to ignite or explode. Improper grounding can cause electric shock. Grounding provides an escape wire for the electric current.

Controller:

DC models - ground the controller by attaching the mounting bracket to a grounded surface.

AC models - ground the controller by attaching the ground wire from the harness to a true earth ground.

Typical 12 VDC Installation

FIG. 2 is an example of 12 VDC installation. Your installation may differ from what is shown here. The Harrier+ controller (G), with wiring, is supplied by Graco. All other components are supplied by the customer. Contact your Graco distributor for assistance in planning a system to suit your needs.

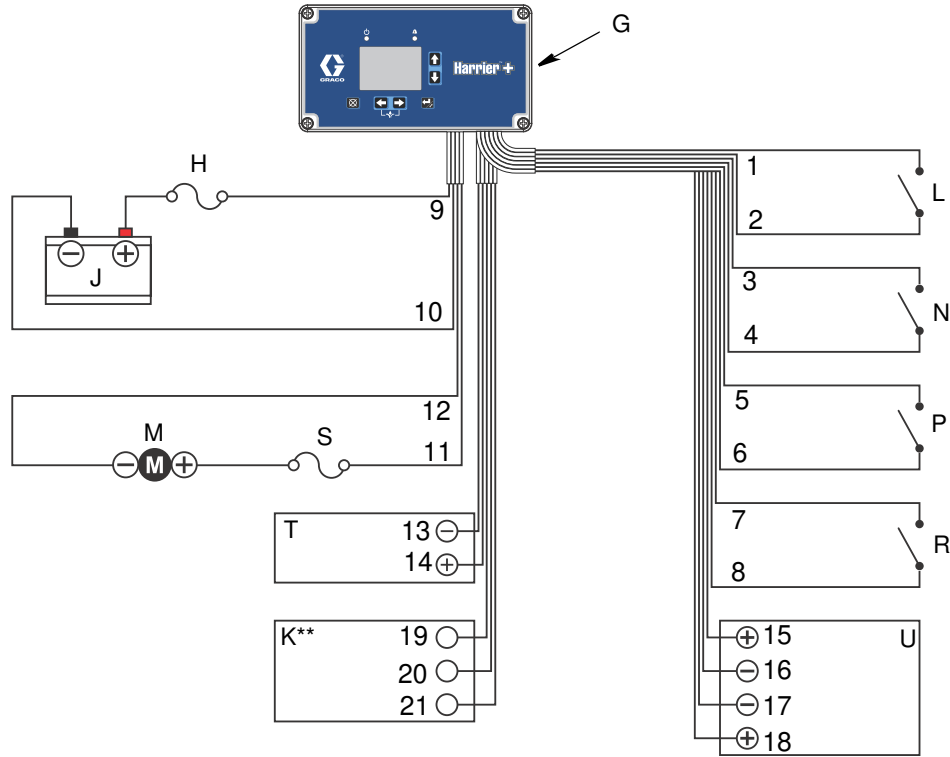

FIG. 2 Typical 12 VDC Installation

Key:

- G** Controller
- H** In-line Fuse* (battery) - UL 248 approved, 20A max (DC)
- J** Battery (12 V)
- K** RS232 SCADA Interface** (optional, SCADA models only)
- L** Auxiliary Switch (optional)
- M** Pump Motor
- N** Cycle Switch for system control
- P** Generic Input 1 (optional)
- R** Generic Input 2 (optional)
- S** In-line Fuse* (pump) - UL 248 approved, 20A max (DC)
- T** Battery Monitor (optional)
- U** Pressure Transducer (optional)

Wiring Key:

- 1 Auxiliary Switch (+), slate
- 2 Auxiliary Switch (-), white
- 3 Cycle Counter (+), orange
- 4 Cycle Counter (-), white/orange
- 5 Alarm #1 (+), brown
- 6 Alarm #1 (-), white/brown
- 7 Alarm #2 (+), yellow
- 8 Alarm #2 (-), white/yellow
- 9 Controller (+), red
- 10 Controller (-), black
- 11 Motor (+), white
- 12 Motor (-), green
- 13 Battery Monitor (-), black
- 14 Battery Monitor (+), red
- 15 +EXE (5VDC), white/red
- 16 -SIGNAL, violet
- 17 +SIGNAL, blue
- 18 -EXE (COM), white/black
- 19 Tx, black (SCADA models only)
- 20 Rx, red (SCADA models only)
- 21 GND, green (SCADA models only)

* UL 248 approved fuses are to be provided by the user.

** RS232 communication is available on SCADA models. Gateway adapters to the controller's RS232 interface must be provided by user to support other protocols.

Typical 120 VAC Installation

FIG. 3 is an example of 120 VAC installation. Your installation may differ from what is shown here. The Harrier+ controller (G), with wiring, is supplied by Graco. All other components are supplied by the customer. Contact your Graco distributor for assistance in planning a system to suit your needs.

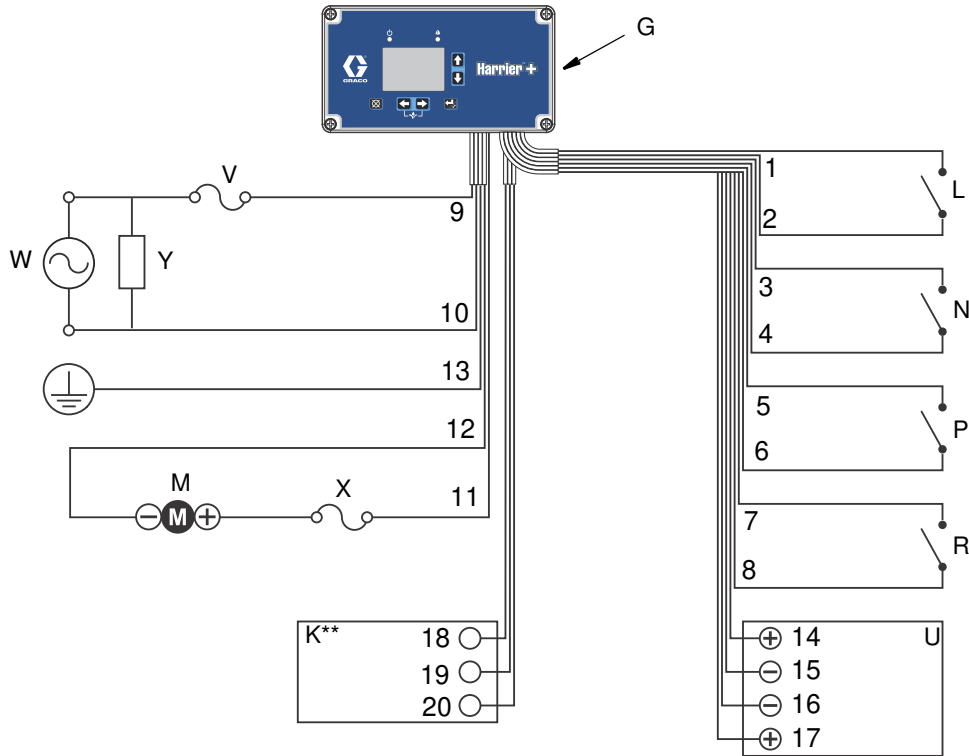

FIG. 3 Typical 120 VAC Installation

Key:

- G** Controller
- K** RS232 SCADA Interface** (optional, SCADA models only)
- L** Auxiliary Switch (optional)
- M** Pump Motor
- N** Cycle Switch for system control
- P** Generic Input 1 (optional)
- R** Generic Input 2 (optional)
- U** Pressure Transducer (optional)
- V** In-line Fuse* (line) - UL 489, Class CC approved, 3A max (AC)
- W** Line power (120 VAC)
- X** In-line Fuse* (pump) - UL 489, Class CC approved, 3A max (AC)
- Y** Surge Protection Device***

* UL 489 approved fuse are to be provided by the user.
 ** RS232 communication is available on SCADA models. Gateway adapters to the controller's RS232 interface must be provided by user to support other protocols.

*** Type 1, Maximum recommended clamping voltage:
 Line-Line: 1500V
 Line-Neutral: 1000V
 Max surge current >= 25kA
 (Required for CE)

Wiring Key:

- 1 Auxiliary Switch (+), slate
- 2 Auxiliary Switch (-), white
- 3 Cycle Counter (+), orange
- 4 Cycle Counter (-), white/orange
- 5 Alarm #1 (+), brown
- 6 Alarm #1 (-), white/brown
- 7 Alarm #2 (+), yellow
- 8 Alarm #2 (-), white/yellow
- 9 Controller (+), black
- 10 Controller (-), white
- 11 Motor (+), red
- 12 Motor (-), green
- 13 Earth Ground, green/yellow
- 14 +EXE (5VDC), white/red
- 15 -SIGNAL, violet
- 16 +SIGNAL, blue
- 17 -EXE (COM), white/black
- 18 Tx, black (SCADA models only)
- 19 Rx, red (SCADA models only)
- 20 GND, green (SCADA models only)

Typical 240 VAC Installation

FIG. 4 is an example of 240 VAC installation. Your installation may differ from what is shown here. The Harrier+ controller (G), with wiring, is supplied by Graco. All other components are supplied by the customer. Contact your Graco distributor for assistance in planning a system to suit your needs.

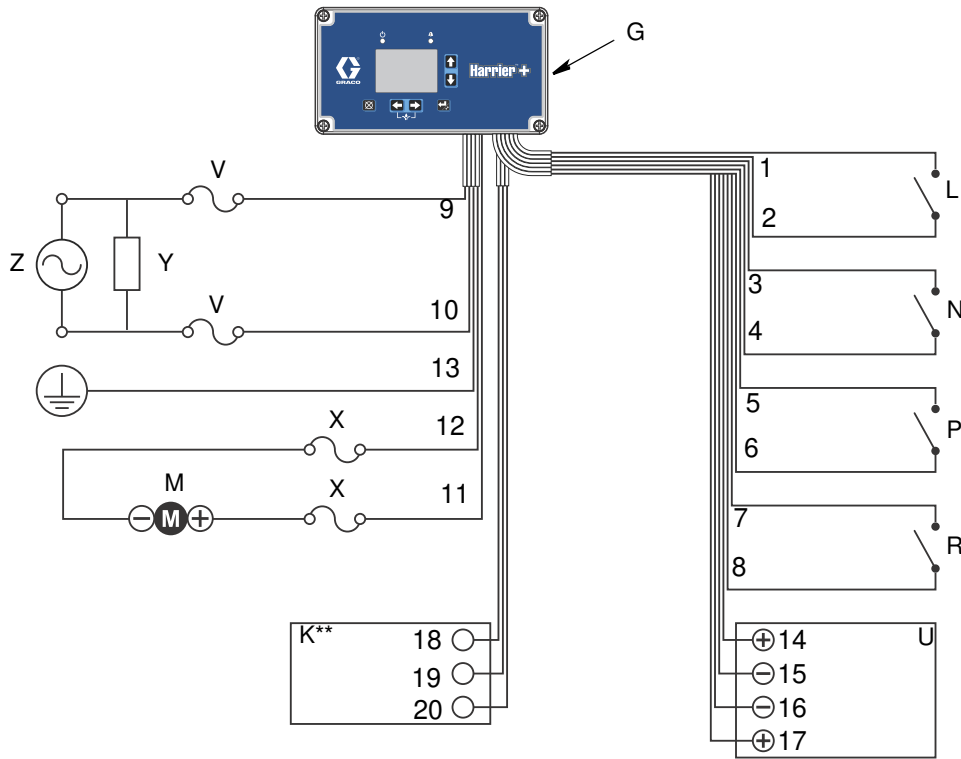

FIG. 4 Typical 240 VAC Installation

Key:

- G** Controller
- K** RS232 SCADA Interface** (optional, SCADA models only)
- L** Auxiliary Switch (optional)
- M** Pump Motor
- N** Cycle Switch for system control
- P** Generic Input 1 (optional)
- R** Generic Input 2 (optional)
- U** Pressure Transducer (optional)
- V** In-line Fuse* (line) - UL 489, Class CC approved, 3A max (AC)
- X** In-line Fuse* (pump) - UL 489, Class CC approved, 3A max (AC)
- Y** Surge Protection Device***
- Z** Line power (240 VAC)

* UL 489 approved fuse are to be provided by the user.

** RS232 communication is available on SCADA models. Gateway adapters to controller's RS232 interface must be provided by user to support other protocols.

*** Type 1, Maximum recommended clamping voltage:
 Line-Line: 1500V
 Line-Neutral: 1000V
 Max surge current >= 25kA
 (Required for CE)

Wiring Key:

- 1 Auxiliary Switch (+), slate
- 2 Auxiliary Switch (-), white
- 3 Cycle Counter (+), orange
- 4 Cycle Counter (-), white/orange
- 5 Alarm #1 (+), brown
- 6 Alarm #1 (-), white/brown
- 7 Alarm #2 (+), yellow
- 8 Alarm #2 (-), white/yellow
- 9 Controller (+), black
- 10 Controller (-), white
- 11 Motor (+), red
- 12 Motor (-), green
- 13 Earth Ground, green/yellow
- 14 +EXE (5VDC), white/red
- 15 -SIGNAL, violet
- 16 +SIGNAL, blue
- 17 -EXE (COM), white/black
- 18 Tx, black (SCADA models only)
- 19 Rx, red (SCADA models only)
- 20 GND, green (SCADA models only)

Theory of Operation

Flow Control Summary

In Flow mode, you can choose the flow rate, or volume, of chemical pumped each day. You can specify either gallons or liters per day, as well as a coefficient representing the plunger diameter and stroke of your pump.

Flow mode is advantageous when accuracy is required.

Cycle Control Summary

In Cycle mode, you can choose the number of cycles per minute. The maximum rate is 60 cycles per minute and will result in a constant running condition.

Cycle mode is advantageous when the highest possible level of chemical rate injection is required.

Time Control Summary

In Time mode, you can choose the on time and off time. Adjusting the on and off times allows the user to control both the dosing of chemical along with the frequency at which the pump runs.

Time mode is advantageous when direct control of the pump's run time is required.

Pump Calibration

The pump should be calibrated using one of the following methods to ensure accuracy of the actual flow rate and totalizers.

K-Factor Method

The K-Factor is a coefficient that represents the plunger diameter and stroke of your pump. The pump can be calibrated by entering the K-Factor (from **K-Factors** table on page 13) on the Pump Setup screens for Flow Mode (page 12) and Cycle Mode (page 14).

Beaker Method

This method requires the user to provide an appropriately-sized beaker based on the size and flow rate of your pump.

Before CALIBRATION is initiated on the **Advanced Setup Screen**, on page 18, direct an outlet line to the calibration beaker. (Refer to the Wolverine Premium Chemical Injection System manual (3A3100) for the location of the outlet line and for the appropriate Pressure Relief Procedure.)

Once initiated, the pump will automatically dispense fluid for five cycles (each cycle being a single rotation of the pump cam, as detected by the cycle switch).

Measure the fluid volume dispensed and enter in the CAL VOLUME field of the Advanced Setup screen, which only appears after the calibration cycles are completed.

Calibration Gauge Method

Refer to **Calibrate Chemical Dosage** in the Wolverine Premium Chemical Injection System manual (3A3100).

Controller Setup



AUTOMATIC SYSTEM ACTIVATION HAZARD

Unexpected activation of the system could result in serious injury, including skin injection and amputation.

This device can automatically dispense fluid as soon as it is returned to the Run screen (see page 19).

2. Use the Up/Down arrows to move the cursor to the Pump Mode Selection box and press Enter to display the list of mode options.
3. Use the Up/Down arrows to move the cursor up and down through the list of Pump Mode options, and press Enter when the desired mode is highlighted.
4. Use the Up/Down arrows to move the cursor up and down through the list of setup screens, and press Enter to display the selected setup screen.

NOTE: The Pump Setup screen is the only screen with content that varies with Pump Mode selection.

Configuration Screen

When you first turn on power to the Injection Controller, the following identification screen displays.



FIG. 5 Splash screen

AA The current Software Version

NOTE: The backlight is on at power-up and will turn off after 30 seconds if no button is pressed.

1. To access the Configuration screen, press and hold the Enter key for 3 seconds.

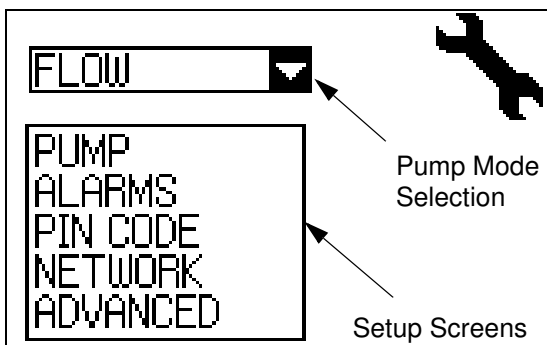

FIG. 6 Configuration screen

5. When all setup operations are complete, press Reset to return to normal operation.

Pump Setup Screen (Flow Mode)

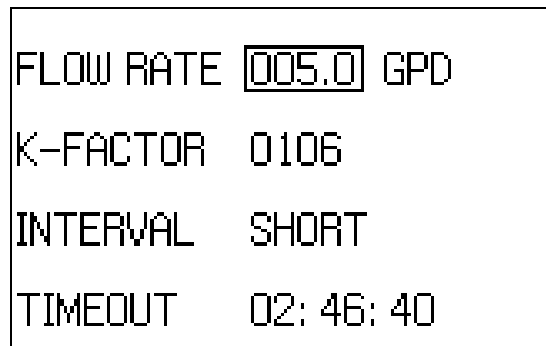

FIG. 7 Pump Setup screen (Flow mode)

The Pump Setup (Flow Mode) screen is used to set the following:

- **FLOW RATE** - The desired number of gallons or liters to be pumped per day.
- **K-FACTOR** - A coefficient representing the amount of fluid that can be dispensed depending on plunger size.
- **INTERVAL** - The length of the pump's On/Off cycle. Use longer intervals for low flow rates.
- **TIMEOUT** - An alarm is triggered if a cycle is not detected within the time specified in the TIMEOUT field. It resets whenever a cycle is detected.

1. On the Configuration screen (FIG. 6), verify FLOW is selected in the pump mode selection box.
2. Select PUMP from the list of setup screens, and press Enter to display the Pump Setup screen for Flow mode.
3. Highlight the FLOW RATE field, and press Enter.
4. Use the arrow keys to highlight and select values for each digit in the desired GPD (gallons per day) or LPD (liters per day) value.
5. Verify the desired value is displayed in the FLOW RATE field, and press Enter.
6. Highlight the K-FACTOR field, and press Enter.
7. Use the arrow keys to highlight and select values for each digit in the desired K-Factor.

NOTE: Use the following table to estimate the K-Factor for your application. You may interpolate between values in the table. Double the values in the table below for configurations with two pumps.

Table 1: K-Factors

Fluid Plunger Pumps	1 in (Full) Stroke	3/4 in Stroke	1/2 in Stroke
1/8 in	40	30	20
3/16 in	90	67	45
1/4 in	159	120	80
3/8 in	359	269	179
1/2 in	637	478	319
5/8 in	996	747	498
3/4 in	1434	1076	717

8. Verify the desired value is displayed in the K-FACTOR field, and press Enter.
9. Highlight the INTERVAL field, and press ENTER.
10. Highlight the desired interval (SMALL=1 minute, MEDIUM=5 minutes, and LONG=10 minutes) and press Enter.
11. Highlight the TIMEOUT field, and press Enter.
12. Use the arrow keys to highlight and select values for each digit in the HH:MM:SS format. This timer runs during the pump On cycle, and will reset whenever

a cycle is detected. When setting this value, allow enough time for at least one cycle to complete.

13. Verify the desired value is displayed in the TIME-OUT field, and press Enter.
14. Press Reset to return to the Configuration screen.

Pump Setup Screen (Time Mode)

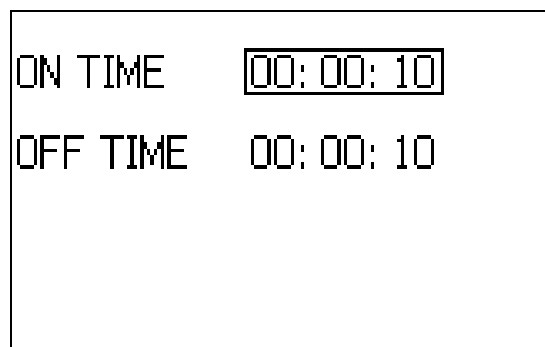

FIG. 8 Pump Setup screen (Time mode)

The Pump Setup (Time Mode) screen is used to set the following:

- **ON TIME** - The desired amount of time the pump is to remain on.
 - **OFF TIME** - The desired amount of time the pump is to remain off.
1. On the Configuration screen (see FIG. 6), verify TIME is selected in the mode selection box.
 2. Select PUMP from the list of setup screens, and press Enter to display the Pump Setup screen for Time mode.
 3. Highlight the ON TIME field, and press Enter.
 4. Use the arrow keys to highlight and select values for each digit in the HH:MM:SS format.
 5. Verify the desired value is displayed in the ON TIME field, and press Enter.
 6. Repeat steps 3-5 for the OFF TIME field.
 7. Press Reset to return to the Configuration screen.

Pump Setup Screen (Cycle Mode)

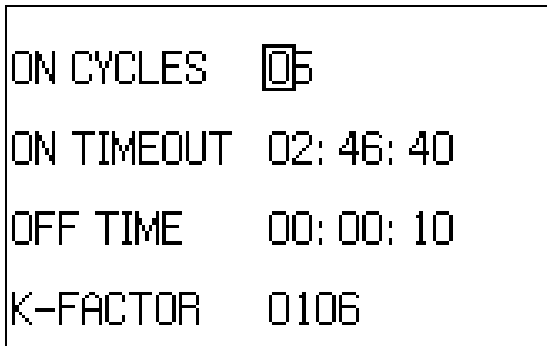

Fig. 9 Pump Setup screen (Cycle mode)

The Pump Setup (Cycle Mode) screen is used to set the following:

- **ON CYCLES** - The desired number of cycles the pump is to remain on. A cycle is defined as a single rotation of the pump cam, as detected by the cycle switch.
- **ON TIMEOUT** - An alarm is triggered if a cycle is not detected within the time specified in the ON TIME-OUT field. It resets whenever a cycle is detected. This timer starts when the value in the OFF TIME field expires.
- **OFF TIME** - The desired amount of time the pump is to remain off after the desired number of cycles in the ON CYCLES field have completed.
- **K-FACTOR** - See **Pump Setup Screen (Flow Mode)** on page 12.

1. On the Configuration screen (see FIG. 6), verify CYCLES is selected in the mode selection box.
2. Select PUMP from the list of setup screens, and press Enter to display the Pump Setup screen for Cycle mode.
3. Highlight the ON CYCLES field, and press Enter.
4. Use the arrow keys to highlight and select values for each digit.
5. Verify the desired value is displayed in the ON CYCLES field, and press Enter.
6. Highlight the ON TIMEOUT field, and press Enter.

7. Use the arrow keys to highlight and select values for each digit in the HH:MM:SS format. This timer runs during the pump On cycle, and will reset whenever a cycle is detected. When setting this value, allow enough time for at least one cycle to complete.
8. Verify the desired value is displayed in the ON TIME-OUT field, and press Enter.
9. Repeat steps 6-8 for OFF TIME field.
10. Highlight the K-FACTOR field, and press Enter.
11. Use the arrow keys to highlight and select values for each digit in the desired K-Factor. (See **K-Factors**, page 13).
12. Verify the desired value is displayed in the K-FAC-TOR field, and press Enter.
13. Press Reset to return to the Configuration screen.

Alarms Setup Screen

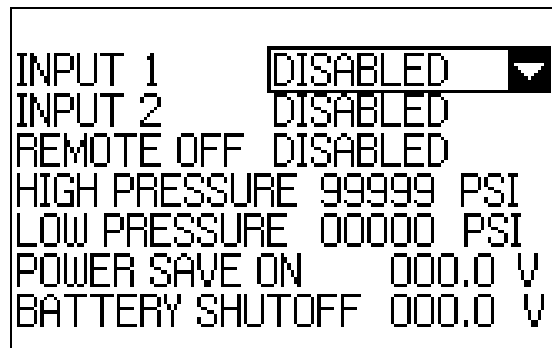

FIG. 10 Alarm Setup screen

The Alarms Setup screen is used to set the following:

- **INPUT 1** - Enable or disable a generic input alarm. When enabled, the alarm can be set for either high or low alarm triggers. See **Alarms and Signal Events**, page 20.
- **INPUT 2** - Enable or disable a generic input alarm. When enabled, the alarm can be set for either high or low alarm triggers. See **Alarms and Signal Events**, page 20.
- **REMOTE OFF** - Enable or disable a remote input event. When enabled, the alarm can be set for either high or low event triggers. See **Alarms and Signal Events**, page 20.

- **HIGH PRESSURE** - An alarm is activated when the pressure is higher than the value specified.
- **LOW PRESSURE** - An alarm is activated when the pressure is lower than the value specified.
- **POWER SAVE ON** -The controller enters Power Save mode when battery voltage drops below the value specified. This field is not displayed when Power Save mode is Off. (See **Advanced Setup Screen**, page 18.)
- **BATTERY SHUTOFF** - An alarm is activated when the battery voltage drops below the value specified. This field is not displayed when Power Save mode is Off. (See **Advanced Setup Screen**, page 18.)

Active High/Low Settings

Active High:

- For INPUT 1 & 2, triggers alarm when signal is high (switch open).
- For REMOTE OFF, puts pump into standby when signal is high (switch open).

Active Low:

- For INPUT 1 & 2, triggers alarm when signal is low (switch closed).
- For REMOTE OFF, puts pump into standby when signal is low (switch closed).

1. On the Configuration screen (see FIG. 6), select ALARMS from the list of setup screens, and press Enter to display the Alarms Setup screen.
2. Highlight the INPUT 1 field, and press Enter.
3. Highlight the desired setting (DISABLE, ACTIVE HIGH, or ACTIVE LOW), and press Enter.
4. Repeat steps 2-3 for the INPUT 2 and REMOTE OFF fields.
5. Highlight the HIGH PRESSURE field, and press Enter.
6. Use the arrows to highlight and select values for each digit in the desired pressure.
7. Verify the desired pressure is displayed, and press Enter.
8. Repeat steps 5-7 for the LOW PRESSURE field.

9. Highlight the POWER SAVE ON field, and press Enter.
10. Use the arrows to highlight and select values for each digit in the desired voltage.
11. Verify the desired voltage is displayed, and press Enter.
12. Repeat steps 9-11 for the BATTERY SHUTOFF field.
13. Press Reset to return to the Configuration screen.

PIN Code Setup Screen

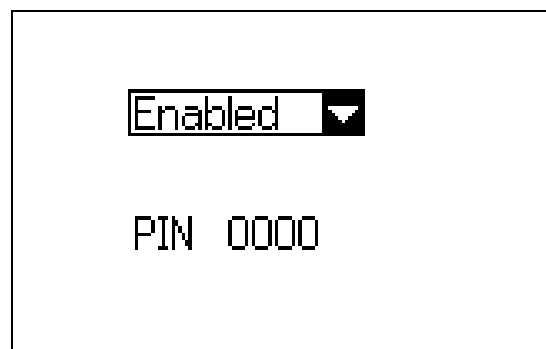

FIG. 11 PIN Code Setup screen

The PIN Code Setup screen allows you to enable a PIN Code Entry screen (see FIG. 12) that prevents access to the Configuration screen (see FIG. 6) without the correct PIN Code.

1. On the Configuration screen (see FIG. 6), highlight PIN CODE and press Enter to display the PIN Code setup screen.
2. Use the arrow keys to highlight the selection box, and press Enter.
3. Use the arrows to highlight either Enabled or Disabled, and press Enter.
4. If you selected Enabled, use the arrow keys to highlight and select the desired value for the each digit in the PIN field.

NOTE: If you do not have the correct PIN code, you will not be able to regain access to the Configuration screen. Record your PIN Code before enabling PIN Code Entry. Contact Graco Customer Support if PIN is forgotten.

5. Verify the desired code is displayed in the PIN field, and press Enter.
6. Press Reset to return to the Configuration screen.

PIN Code Entry Screen



FIG. 12 PIN Code Entry screen

The PIN Code Entry screen appears before the Configuration screen only if PIN Code Entry was enabled on the PIN Code Setup screen (see 11).

1. Hold down the Enter key for 3 seconds to display the PIN Code Entry screen.
2. Use the arrows to highlight and select a value for each digit in the PIN code.
3. Verify the desired PIN code is displayed, and press Enter.
 - If the PIN code you entered is correct, the Configuration screen is displayed.
 - If the PIN code you entered is incorrect, the PIN Code Entry screen remains displayed. The Code must be re-entered by repeating step 2.

Network Setup Screen

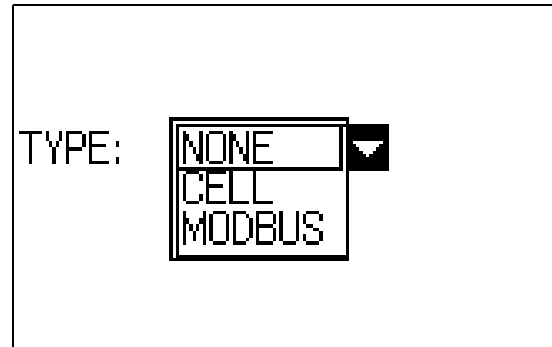

FIG. 13 Network Setup screen

The Network Setup screen is used to set the following:

- **CELL** - Allows controller to communicate to Harrier+ web portal. Only for controllers with cell modems. See **Models** on page 3.
 - **MODEBUS** - Enables Modbus communication between the controller and a Supervisory Control and Data Acquisition (SCADA) system to remotely monitor and control your pump. (See **Typical Installations**, starting on page 8.) Only for SCADA systems without a cell modem. See **Models** on page 3.
1. On the Configuration screen (see FIG. 6), select NETWORK from the list of setup screens, and press Enter to display the Network Setup screen (see FIG. 13).
 2. Use the arrows to highlight the TYPE field, and press Enter.
 3. Use the Up/Down arrows to highlight the desired network connection, and press Enter.
 4. Turn the Harrier+ controller Off and On after changing TYPE.

Cell Network Setup

1. From the Network Setup screen, select CELL in the TYPE field and press Enter to display the Activation Code screen.

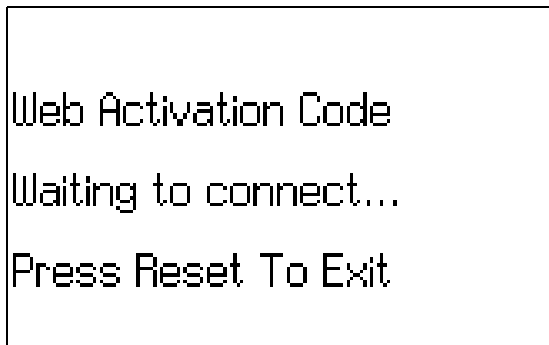

FIG. 14 Activation Code screen

If you press the Reset key while waiting to connect and return to the Network Setup screen, You will see the following screen.

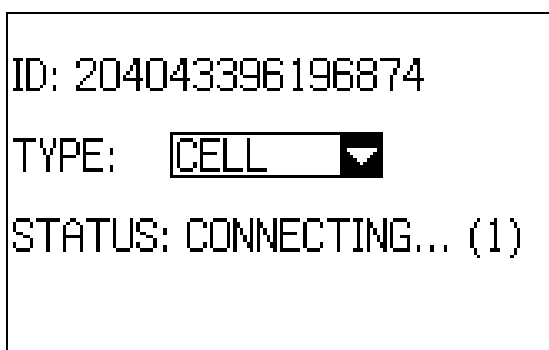

FIG. 15 Cell network connecting

Once connected, the network screen will display the pump name, pump ID, and signal strength.

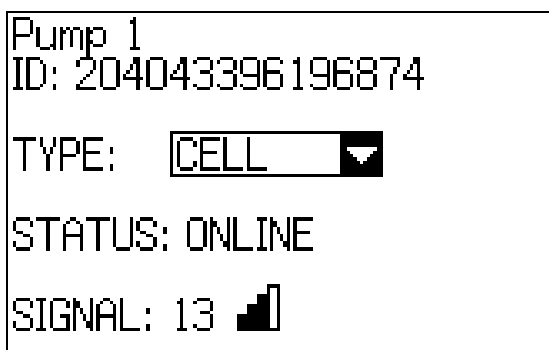

FIG. 16 Cell network connected

It is optimal to have more than one bar of signal strength. If you do not, you may move the equipment for better reception, or refer to **Troubleshooting** on page 38.

2. With CELL selected and STATUS: ONLINE, press the Enter key to display the Web Activation Code. This code is required for remote access to the pump when **Creating a New Account** on page 22.

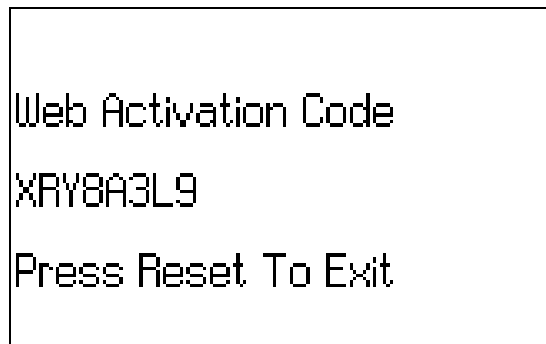

FIG. 17 Cell network Web Activation Code

3. Press Reset to return to the Network Setup screen.

Modbus Network Setup

With MODBUS selected, a SLAVE ID field will appear. See **Appendix A: Modbus Interface**, page 42, for details on interfacing with the controller.

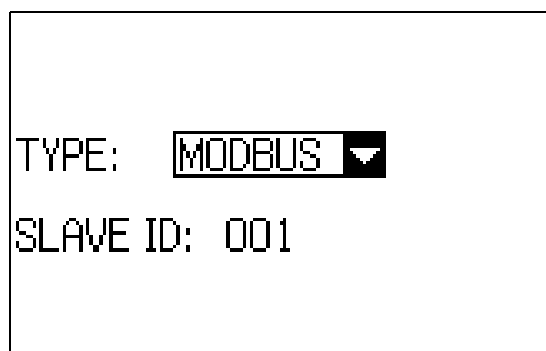

FIG. 18 Network Setup screen

1. Highlight the SLAVE ID field, and press Enter. The slave ID identifies the Harrier+ controller within the SCADA system. Each controller in the SCADA system must have a unique slave ID between 1 and 247.
2. Use the arrow keys to highlight and select a value for each digit of the slave ID, and press Enter.
3. Press Reset to return to the Configuration screen.

Advanced Setup Screen

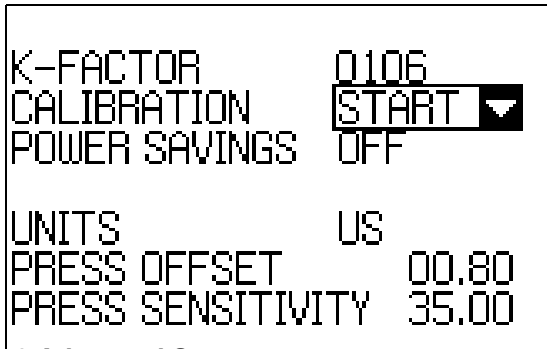

Fig. 19 Advanced Setup screen

The Alarms Setup screen is used to set the following:

- **K-FACTOR** - The current K-Factor. It cannot be edited on this screen, though it is automatically updated during calibration.
- **CAL VOLUME** - The volume pumped during calibration. Only appears during calibration.
- **CALIBRATION** - Calibrates the pump by automatically setting the K-Factor according to the volume dispensed. This will override any previous K-Factor entries on other setup screens. Calibration of the K-Factor is optional, though it does affect the accuracy of the actual flow rate and totalizers.

Calibration can be stopped in one of two ways:

- Selecting STOP in this field.
- Timing out based on the time entered in the TIMEOUT field of either the Pump Setup (Flow Mode) or (Cycle Mode) screens.
- **POWER SAVINGS** - Specifies the action taken by the controller when the pump enters Power Save mode (see **Alarms Setup Screen**, page 14). This is an optional feature that requires a battery monitor. (See **Typical 12 VDC Installation**, page 8.) Actions include:
 - OFF - Turn Power Save mode Off.
 - NOTIFY - Warns user of low battery, but does not reduce pump On time.
 - MIN - Reduces pump On time to 75%.
Ex: If On Time = 60 seconds, the pump will only run for 45 seconds.
 - NORMAL - Reduces pump On time to 50%.
Ex: If On Time = 60 seconds, the pump will only run for 30 seconds.

- **MAX** - Reduces pump On time to 25%.
Ex: If On Time = 60 seconds, the pump will only run for 15 seconds.

- **UNITS** - Specifies whether units are displayed as US or metric.
- **PRESS OFFSET**- The calibration offset value from the pressure transducer label. This is an optional feature that requires a pressure transducer. (See **Typical Installations** starting on page 8.)
- **PRESS SENSITIVITY** - The calibration sensitivity value from the pressure transducer label. This is an optional feature that requires a pressure transducer. (See **Typical Installations** starting on page 8.)

1. On the Configuration screen, select ADVANCED from the list of setup screens, and press Enter to display the Advanced Setup screen.

<p>This device automatically dispenses fluid once START is selected in the CALIBRATION field. To reduce the risk of serious injury, including skin injection, ensure that hands are clear of the outlet line and that a calibration beaker is in place before starting calibration.</p>				

2. Only if pump calibration is needed, highlight CALIBRATION and press Enter.
3. Highlight START or STOP, and press Enter.
4. Highlight POWER SAVINGS and press Enter.
5. Highlight the desired power savings action (OFF, NOTIFY, MIN, NORMAL, or MAX), and press Enter.
6. Highlight UNITS and press Enter.
7. Highlight US or METRIC, and press Enter.
8. If pressure transducer calibration is desired, highlight PRESS OFFSET and press Enter.
9. Use the arrows to highlight and select a value for each digit of the pressure offset.
10. Verify the desired value is displayed in the PRESS OFFSET field, and press Enter.

11. If pressure transducer calibration is desired, highlight PRESS SENSITIVITY and press Enter.
12. Use the arrows to highlight and select a value for each digit of the pressure sensitivity.
13. Verify the desired value is displayed in the PRESS SENSITIVITY field, and press Enter.
14. Press Reset to return to the Configuration screen.

Run Screens

Screen Identification

The following screen is only shown as an example of the information that is displayed on a Run screen. A complete description of the icons and symbols shown in FIG. 20 is provided on page 5.

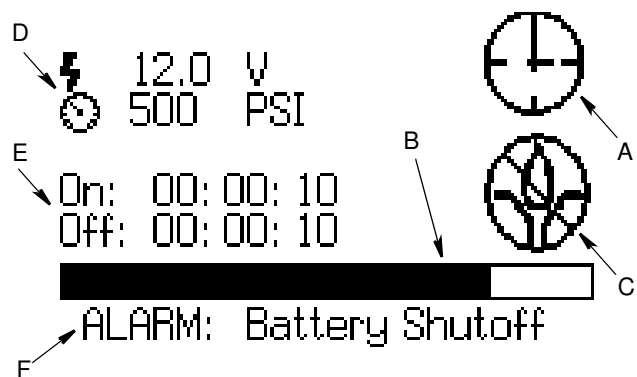

FIG. 20 Run Screen

- A Operating Mode Identification** - Displays Flow Mode Active, Time Mode Active, or Cycle Mode Active icons depending on which metering mode is selected.
- B Progress Bar** - Real-time, visual representation of the elapsed time during a Pump On or Pump Off cycle.
- C Pump On/Off Indicator** - Visual indication of whether the pump is completing an On Cycle or Off Cycle.
- D DC Voltage & Pressure** - Real-time voltage and pressure values. DC Voltage is not displayed when Power Save mode is Off. Pressure appears for both AC and DC models. Displays 0 PSI when no pressure transducer is connected. See **Advanced Setup Screen**, page 18.
- E Pump Run Summary** -
 - Flow Mode - Displays current desired Flow Rate
 - Time Mode - Displays current desired On and Off Times
 - Cycle Mode - Displays current desired On Cycle and Off Time
- F Status Line** - Area where status messages are displayed.

Alarms and Signal Events

When an alarm or signal event occurs, the Run screen displays a status message indicating an alarm or event is active (see F on FIG. 20) and the Function LED (see FIG. 1) is lit. When an alarm or event is active, the pump goes into Standby mode.

To clear an alarm,





- Press the Reset key on the controller (see **Keypad, Display, and Icons**, page 5).
- Press the Reset icon on the Web application (see **Pumps Detail Screen (Pump Connected)**, page 27). Available on CDMA and GSM models. (See **Models**, page 3.)
- Send a Reset command through the SCADA interface using the Modbus map (see **Appendix A: Modbus Interface**, page 42). Available on SCADA models. (See **Models**, page 3.)

The following is a list of alarm events that may display.

Table 2: Alarm Events

Name	Type	Trigger Condition	Fixes and Actions
Input 1 Ex. Tank Switch	Alarm	Switch activated according to the Active High / Active Low setting on the Alarms Setup Screen , page 14. Ex: Tank level is low	Check the device being monitored and reset the alarm. Ex: Refill the tank and press Reset on the controller.
Input 2	Alarm	Switch activated according to the Active High / Active Low setting on the Alarms Setup Screen , page 14.	Check the device being monitored and reset the alarm.
Disabled by Remote Ex. Temperature Switch	Signal Event	The remote input sets the pump to Standby mode automatically according to the Active High / Active Low settings on the Alarms Setup Screen , page 14.	None required. The signal event automatically clears and sets the pump to Run mode without input from the user.
High Pressure	Alarm	Pressure above the threshold set by user on the Alarms Setup Screen , page 14.	Check the system pressure and reset the alarm.
Low Pressure	Alarm	Pressure below the threshold set by user on the Alarms Setup Screen , page 14.	Check the system pressure and reset the alarm.
Counts Not Achieved	Alarm	Cycle switch signal not detected within the value specified in the Timeout fields of the Pump Setup Screen (Flow Mode) , page 12, and the Pump Setup Screen (Cycle Mode) , page 14.	Replace the cycle switch and reset the alarm.
Low Battery	Alarm	Battery voltage is below the value specified in the Battery Shutoff field of the Alarms Setup Screen , page 14.	Check solar panel connection. Replace battery. Alarm clears automatically when voltage is > threshold + 0.5V, or when the alarm is reset.

Harrier+ Web Portal

				
AUTOMATIC SYSTEM ACTIVATION HAZARD				
<p>Unexpected activation of the system could result in serious injury, including skin injection and amputation.</p>				
<p>This device has an automatic timer that activates the chemical injection system when power is connected or when exiting the programming function. The device can also be activated remotely from internet portals. Before you install or remove the controller from the system, disconnect and isolate all power supplies, and relieve all pressure.</p>				

The Harrier+ Web Portal allows you to remotely monitor and control your chemical injection pump from any computer or device with Internet access.

NOTE: Web Portal screens may be subject to continuing updates. See harrier.graco.com for updates and the most recent information.

Creating a New Account

1. Go to <https://harrier.graco.com> to display the Graco login screen and select **Register new account** to display the Register New Account screen.



Register » New account

All fields are required.

EMAIL	<input type="text" value="Email"/>
FIRST NAME	<input type="text" value="First name"/>
LAST NAME	<input type="text" value="Last name"/>
PASSWORD	<input type="text" value="New password"/>

The pump activation key is displayed on the pump controller's network configuration screen. Choose "cell" from the drop-down menu on the controller to display the key.

PUMP ACTIVATION KEY	<input type="text" value="Pump activation key"/>
---------------------	--

Choose a name for your group below. This will create a new group. Good choices could include your company or your division. If you want to join an existing group, have the group manager send you an invitation from the group's page.

GROUP	<input type="text" value="Group"/>
-------	------------------------------------

Register

FIG. 21 Register New Account screen

2. Fill in the fields on the Register New Account screen, following the on-screen instructions, and click **Register** to display the Account Pending screen. Call Graco Customer Support if you need assistance.



Account pending

Thank you for registering!

We've sent you an account activation message to the email address you provided. To finish activating your account, follow the link in that email.

If you don't receive an email from us within the next hour, please be sure to check your spam or junk folder.

Pump Control v1.0.281

FIG. 22 Account Pending screen

3. Check your email for an account activation message from Graco. Follow the instructions to activate your account and to display the Activation Complete screen.



Activation complete

Thank you for verifying your email address. Your account is now active.

You may log in now using your email address and the password you specified when setting up your account.

If did not set a password for your account, you can do so by using the [Forgot Password](#) link on the login page.

[Return to login page](#)

Pump Control v1.0.290

FIG. 23 Activation Complete screen

4. Click **Return to login page** to log in to the account.

Logging In to the Web Portal

1. Go to <https://harrier.graco.com> to display the Graco login screen.



Email address

Password

Stay logged in

Log in

[Register new account.](#)

[Forgot password?](#)

Pump Control v1.0.290

FIG. 24 Graco Login screen

2. Enter your username and password.

NOTE: Uncheck the **Stay logged in** box for maximum security to prevent unintended users from accessing your account.

3. Click **Log in** to display the Pumps List screen.

NOTE: The Terms of Service screen is displayed the first time you log in with a new account. The Pumps List screen is displayed once you've read and agreed to the Terms of Service.



[Pumps](#) [Groups](#) [Settings](#) [Help](#)

Terms of service

You must read and agree to the updated Terms of Service shown below to continue using this site.

End User License Agreement (EULA)

Graco Inc. agrees to provide you access to and use of its Software, under the terms and conditions specified below:

Configuration

You agree to use this Software with at least the minimum hardware and software requirements as set forth in the product documentation.

License Grant

Graco grants you a license to use the Software. "Use" means storing, loading, installing, executing or displaying the Software. You may not modify the Software or disable any licensing or control features of the Software. You agree to use the Software only in conjunction with Graco hardware.

Pump Control v1.0.281

FIG. 25 Terms of Service screen

Pumps List Screen

The Pumps List screen lists all of the available pumps in your group. The Pumps table features the following information:

- **Name** - This is the name of the pump within the group.
- **Group** - This is the name of pump's group, which is a user-defined collection or network of pumps and the users authorized to remotely view and control those pumps. It may be a company or a collection of users within a company. Group users are able to remotely view and control all pumps within the group. Refer to **Groups Detail Screen**, page 33.
- **Status** - This indicates whether the pump is running, on standby, offline, disabled by alarm, disabled by remote, or in power save mode.



[Pumps](#) [Groups](#) [Settings](#) [Help](#)

Pumps

Name	Group	Status
Pump 1	Example Group	Standby

Pump Control v1.0.290

FIG. 26 Pumps List screen

You can view the status of any pump in the network by clicking the name of the pump. This will display the Pump Detail screen, which differs depending on whether the pump is connected or disconnected.

- If the pump is connected, the Pump Detail screen will display a variety of information about the pump (see FIG. 27).
- If the pump is disconnected, you will see the Pump Detail screen shown in FIG. 30.

Pumps Detail Screen (Pump Connected)

The Pumps Detail screen shown below is an example of the information available for a single connected pump. The information displayed below will vary depending on the pump metering mode. This screen is displayed when you click name of a connected pump on the Pumps List screen (FIG. 26).

GRACO Pumps Groups Settings Help

Pumps » Pump 1

NAME	Pump 1	
STATUS	Standby	
ALARMS ACTIVE	None	
METERING MODE	Flow	
FLOW RATE	8.0 gal / day	
TOTALIZER	23.8 gal	
GRAND TOTALIZER	95.6 gal	
HISTORICAL CHARTS		
MAINTENANCE REMINDERS		
POWER SAVE MODE	Off	
PRESSURE LEVEL	184.0 PSI	
HIGH PRESSURE ALARM	1000 PSI	
LOW PRESSURE ALARM	100 PSI	
NETWORK	Connected	
SIGNAL STRENGTH	26	
LOCATION	<Not set>	
MARKED LOCATION	45.02190, -93.24500	
GROUP	Example Group	
PUMP ID	310006186105226	
DOWNLOAD HISTORY		
FIRMWARE VERSION	1. 1. 2	

FIG. 27 Pumps Detail screen (pump connected)

The following information is available on this screen:

- **NAME** - This the name of the pump within the network. It can be edited by clicking the icon and entering a new name in the text box that appears.
- **STATUS** - This indicates the current network status of the pump. The icon can be used to toggle between Run and Standby. Putting the pump in Run mode will immediately start the pump. If the status indicates the pump has been disabled by an alarm or remote, you will not be able to change the status until you reset the alarm in the ALARMS ACTIVE row.
- **ALARMS ACTIVE** - This indicates whether there are any active alarms for the pump. Any active alarms puts the pump into Standby mode, and the STATUS row will indicate that the pump is disabled by Alarm or Remote. You can reset active alarms by clicking the Reset icon in the Alarms Active row. The Reset icon only appears when an alarm is active.
- **METERING MODE** - This indicates whether the pump is running in Flow, Time, or Cycle mode. Some of the information on this screen is specific to a particular metering mode, and may not appear for all modes. The metering mode can only be changed from the Harrier+ controller on the Configuration screen. The information for each mode is listed below.

Flow Mode

- **FLOW RATE** - This is the desired number of gallons or liters to be pumped per day.
- **TOTALIZER** - This is the number of gallons pumped since last time the Totalizer was reset. The Totalizer is reset by clicking the icon.
- **GRAND TOTALIZER** - This the total number of gallons pumped since the pump was added to the network. It cannot be reset.

Time Mode

- **ON TIME** - This is the desired amount of time the pump is to remain on.
- **OFF TIME** - This is the desired amount of time the pump is to remain off.

Cycle Mode

- **ON CYCLES** - This is the desired number of cycles the pump is to remain on.
- **ON TIMEOUT** - An alarm is triggered if a cycle is not detected within the time specified in the ON TIMEOUT field. This timer starts when the value in the OFF TIME field expires.
- **OFF TIME** - This is the desired amount of time the pump is to remain off after the desired number of cycles in the ON CYCLES field have completed.

- HISTORICAL CHARTS** - Clicking the icon displays the Historical Charts screen. For chart data, you may choose from Total pumped per day (the actual volume pumped, not the desired setting), Battery voltage, or Fluid pressure. For days to show, you may choose from the past 1, 7, 14, 30, or 90 days.

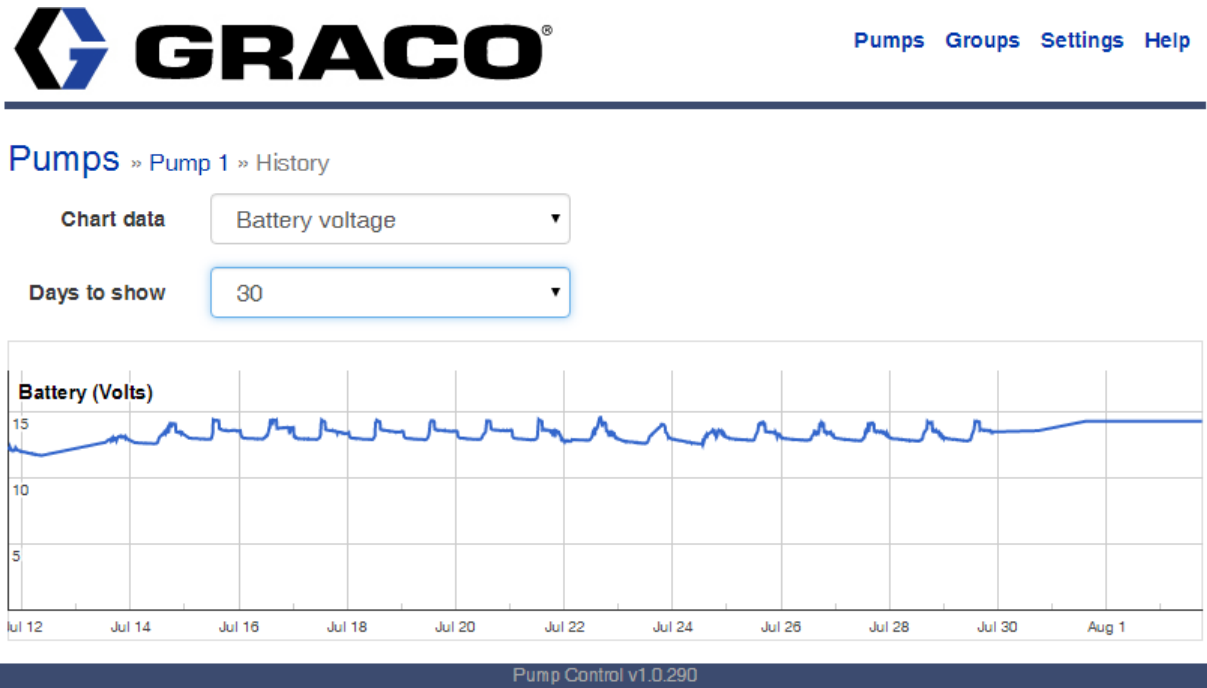

Fig. 28 History Chart of Battery Voltage for 30 days

- MAINTENANCE REMINDERS** - Clicking the icon displays the Maintenance Reminders screen, which allows you to add maintenance reminders; or lists any active reminders (such as Pump Service), their regularity, and when they are next due. Clicking Add Maintenance Reminder allows you to choose the type of reminder (Pump Service, Motor Service, Battery Service, and Chemical Tank Refill) and period (Immediate, or 1, 3, 6, 12, or 24 months). Reminders can also be customized by both subject and period (in months).

Subject	Period	Next due	Delete
Pump Service	6 months	2016/02/12	
Motor Service	6 months	2016/02/12	

[Add Maintenance Reminder](#)

Fig. 29 Maintenance Reminders screen

- **POWER SAVE MODE** - This field only appears when the Power Save mode is off. The following three fields (BATTERY VOLTAGE, POWER SAVE ON, and BATTERY SHUTOFF) will not appear when Power Save Mode is off.
- **BATTERY VOLTAGE** - Displays the current battery voltage if the optional battery monitor is connected.
- **POWER SAVE ON** - This is the battery voltage threshold at which Power Save mode is triggered. It can be edited by clicking the icon and entering a new voltage value in the text box that appears.
- **BATTERY SHUTOFF** - This is the battery voltage threshold for a low battery alarm to be triggered. It can be edited by clicking the icon and entering a new voltage value in the text box that appears.
- **PRESSURE LEVEL** - Displays the current pressure level if the optional pressure transducer is connected.
- **HIGH PRESSURE ALARM** - This is the pressure threshold for a high pressure alarm to be triggered. It can be edited by clicking the icon and entering a new pressure value in the text box that appears.
- **LOW PRESSURE ALARM** - This is the pressure threshold for a low pressure alarm to be triggered. It can be edited by clicking the icon and entering a new pressure value in the text box that appears.
- **NETWORK** - This indicates whether the pump has network connectivity.
- **SIGNAL STRENGTH** - This is the network signal strength.
- **LOCATION** - This is a description of the pump's location. It can be edited by clicking the icon and entering a new location in the text box that appears.
- **MARKED LOCATION** - This is the longitude and latitude for the pump's location. This can be edited by the icon. You can either directly enter the longitude and latitude, or click the **Get Location** button to download your current coordinates. You can display a map view of your pump's location by clicking the coordinates.
- **GROUP** - This the name of group that was created or selected during account registration. Pumps are assigned to a group during account registration, or to an existing group at any time.
- **ACTIVATION KEY** - The Activation Key ties a pump (as identified by its Pump ID) to its assigned group. The Activation Key is generated at the pump by selecting "CELL" on the Network Setup screen. This field will only appear on this screen for group managers and administrators.
- **PUMP ID** - This is the Harrier+ controller's unique pump ID.
- **DOWNLOAD HISTORY** - Clicking the icon downloads a CSV file with a log of all data sent to and from the pump; such as, firmware updates, changes to settings, and status updates.
- **FIRMWARE VERSION** - This is the version number of the firmware running on the Harrier+ controller.

Pumps Detail Screen (Pump Disconnected)

The Pumps Detail screen shown below is an example of the information available for a single disconnected pump. This screen is displayed when you click name of a disconnected pump on the Pumps List screen (FIG. 26).

The screenshot shows the GRACO web portal interface. At the top left is the GRACO logo. To the right are navigation links: Pumps, Settings, and Help. Below the navigation is a breadcrumb trail: Pumps » Pump 1. The main content area is a table with the following rows:

NAME	Pump 1	
HISTORICAL CHARTS		
MAINTENANCE REMINDERS		
NETWORK	Not connected	
LAST CONNECTED	2015-06-02 17:04:40 CDT	
PUMP ID	270113182612191782	

FIG. 30 Pumps Detail screen (pump disconnected)

The following information is available on this screen:

- **NAME** - This is the name of the pump within the network. It can be edited by clicking the icon and entering a new name in the text box that appears.
- **HISTORICAL CHARTS** - Clicking the icon displays the Historical Charts screen. For chart data, you may choose from Volume per Day, Battery, or Pressure. For days to show, you may choose from the past 1, 7, 14, 30, or 90 days.
- **MAINTENANCE REMINDERS** - Clicking the icon displays the Maintenance Reminders screen, which lists any active reminders, such as Pump Service, their regularity, and when they are next due. Clicking Add Maintenance Reminder allows you to choose the type of reminder (Pump Service, Motor Service, Battery Service, and Chemical Tank Refill) and period (Immediate, or 1, 3, 6, 12, or 24 months).
- **NETWORK** - This indicates whether the pump has network connectivity.
- **LAST CONNECTED** - This is the last date and time the Harrier+ controller had network connectivity.
- **PUMP ID** - This is the Harrier+ controller's unique pump ID.

Groups List Screen

The Groups List screen displays the groups you belong to. This screen is displayed when you click the Groups link at the top of any screen.



[Pumps](#) [Groups](#) [Settings](#) [Help](#)

Groups

Name	Pump count	User count
Example Group	1	1

[Create group](#)

Pump Control v1.0.290

FIG. 31 Groups List screen

The following information is available on this screen:

- **Name** - This the name of all the groups you belong to. You can click any name to display a Groups Detail screen for the group (FIG. 32).
- **Pump count** - The number of pumps currently in a group.
- **User count** - The number of users currently in a group.

Groups Detail Screen

The Groups Detail screen displays information about a group, including the group’s manager, members, and pump. This screen is displayed by clicking the name of a group on the Groups List screen (FIG. 31).



FIG. 32 Group Detail screen

The following information is available on this screen:

- **NAME** - This the name of the group. It can be edited by clicking the icon and entering a new name in the text box that appears.
- **MANAGER** - This is email address of the group’s manager. They can edit exiting group fields, as well as add and delete users and pumps.
- **USERS** - Users can remotely view and control all pumps associated with the group. Click the icon to display a list of existing group users. Managers can use this screen to invite new users to the group and to remove existing users.



FIG. 33 Group User List screen

- **PUMPS** - Pumps associated with the group can be viewed and controlled by users in the group. Click the icon to display a list of all pumps associated with the group. Managers can use this screen to add and remove associated pumps.



[Pumps](#) [Groups](#) [Settings](#) [Help](#)

[Groups](#) » [Example Group](#) » Pumps

Name	Status	Remove
Pump 1	Standby	<input type="button" value="⊘"/>

[Add pump to group](#)

Pump Control v1.0.290

FIG. 34 Groups Pumps screen

Invitation to Join a Group

If you want to join an existing group, the group manager can send you an invitation to join the group. You will receive an email from Graco inviting you to join the group. Click the link in the email to accept the invitation and display the Invitation screen shown in FIG. 35.



FIG. 35 Accept Invitation screen

Once you have accepted the invitation, you are able to remotely view and control all of the pumps in all of your groups. These pumps are added to your Pumps List screen.



FIG. 36 Pumps List screen after new group invitation

Settings Screen

The Settings screen allows you to view and edit your user settings. This screen is displayed when you click the Settings link at the top of any screen.



[Pumps](#) [Groups](#) [Settings](#) [Help](#)

Users » username@example.com

EMAIL	username@example.com	
PASSWORD		
FIRST NAME	John	
LAST NAME	Smith	
TIME ZONE	UTC	
DISPLAY UNITS	U.S.	
SHOW DISCONNECTED PUMPS	Yes	<input type="checkbox"/>
ENABLE REMINDERS	Yes	<input type="checkbox"/>
MAINTENANCE REMINDERS		
GROUPS	Example Group	

[Log out](#)

Pump Control v1.0.290

Fig. 37 Users screen

The following information is available on this screen:

- **EMAIL** - This is the email address associated with your username. You can edit this by clicking the icon and entering a new email address in the text box that appears.

- **PASSWORD** - This is your login password. You can edit this by clicking the icon and entering a new password in the text box that appears.
- **FIRST NAME** - Your first name.
- **LAST NAME** - Your last name.
- **TIME ZONE** - This is your time zone. You can edit this by clicking the icon and selecting another time zone from the drop-down menu that appears.
- **DISPLAY UNITS** - This indicates what units of measurement are used on screens and charts. You can edit this by clicking the icon and selecting either US or Metric from the drop-down menu that appears.
- **SHOW DISCONNECTED PUMPS** - This indicates whether the Pump List screen defaults to including disconnected pumps. You can toggle between Yes and No by clicking the icon.
- **ENABLE REMINDERS** - This indicates whether maintenance reminders are enabled. You can toggle between Yes and No by clicking the icon.
- **MAINTENANCE REMINDERS** - Clicking the icon displays the Maintenance Reminders screen, which lists any active reminders, such as Pump Service, their regularity, and when they are next due. Clicking Add Maintenance Reminder allows you to choose the type of reminder (Pump Service, Motor Service, Battery Service, and Chemical Tank Refill) and period (Immediate, or 1, 3, 6, 12, or 24 months).
- **GROUPS** - The groups you belong to.

Help Screen

The Help screen directs to you resources for additional information about technical support, related products, and patent information. This screen is displayed when you click the Help link at the top of any screen.



[Pumps](#) [Groups](#) [Settings](#) [Help](#)

Help

Technical support

If you have questions or encounter problems while using the web site, please contact us at oilandgas@graco.com.

Related products

Graco offers a wide array of related products and services. For more information, please visit the [main Graco web site](#).

Patent information

For patent information, see www.graco.com/patents.

Terms of Service

Use of this site is subject to the [Terms of Service](#).

Pump Control v1.0.290

FIG. 38 Help screen

Troubleshooting



Description	Problem	Solution
Unit does not power on or display is dim/unresponsive	Incorrect or loose wiring	Refer to Installation , page 7.
	Input voltage is out of range	Confirm power source is with the correct range.
	Tripped external fuse	Verify proper connections. Refer to Installation , page 7.
	Incorrect operating temperature	Verify ambient temperature is within recommended operating conditions.
Pressure transducer reading not working or inaccurate	Pressure transducer not calibrated	Refer to the Advanced Setup Screen , page 18, for calibration information.
	Pressure transducer faulty	Replace pressure transducer
Pump not running	No power	Check wiring. Refer to Installation , page 7.
	There is an alarm	Check alarms. Refer to Alarms and Signal Events , page 20.
	Other	See Wolverine Chemical Injection Pump manual (334513).
Battery monitor not working	Not connected	Check wiring. Refer to Installation , page 7.
	Battery voltage too low	Check battery and wiring to the solar panel.
	Not enabled	Check setup screens. Refer to the Alarms Setup Screen , page 14, and to the Advanced Setup Screen , page 18.
Not connecting to a cell network	No signal	Check antenna orientation and mounting. Make sure antenna is pointing upwards towards sky. Make sure device is not located in a concrete building or near other interfering devices.
		Verify antenna cables are connected. Use only the antenna provided.
		Check cell service in the area.
	Incorrect network mode	Select CELL on the Network Setup Screen , page 16, and turn power to the controller Off and On.
	Modem not supported	Verify correct controller model for cell networks. Refer to Models , page 3.

Description	Problem	Solution
Not connecting to a SCADA network	Incorrect network mode	Select MODBUS on the Network Setup Screen , page 16, and turn power to the controller Off and On.
	Incorrect slave ID	Verify the correct slave ID has been assigned to the controller on the Network Setup Screen , page 16, and turn power to the controller Off and On.
	Incorrect registers or values sent to the controller	Refer to Appendix A: Modbus Interface , page 42, for details on interfacing with the controller.
	Incorrect wiring	Check wiring. Refer to Installation , page 7, and verify the proper user-provided gateway adapter is connected correctly.

Program Settings

Description	Page	Modes of Operation, Maximums / Minimums, and Additional Comments
Pump Modes	12-14	Flow, Time, Cycle
Flow Rate (Flow Mode)	12	0.1 - 999.9 GPD / LPD. Restricted by K-Factor. Will automatically re-adjust value entered if K-Factor isn't large enough to support flow rate entered.
KFactor (Flow & Cycle Modes)	12-14	1 - 9999.
Interval (Flow Mode)	12	Short, Medium, Long
Time Setup Parameters (All Modes)	12-14	HH:MM:SS (00:00:01 - 23:59:59)
On Cycles (Cycle Mode)	14	01 - 99
Input 1	14	Disabled, Active High, Active Low
Input 2	14	Disabled, Active High, Active Low
Remote Off (Auxiliary Switch)	14	Disabled, Active High, Active Low
High Pressure Trigger	14	00000 - 99999 PSI
Low Pressure Trigger	14	00000 - 99999 PSI
Power Savings	18	Off, Notify, Min, Normal, Max
Power Save On	14	000.0 V - 999.9 V
Battery Shutoff	14	000.0 V - 999.9 V
PIN Number Setup	15	Enabled, Disabled
PIN Code Entry	16	0000 - 9999
Network Type	16	None, Cell, Modbus
Calibration	18	Stop, Start. Updates K-Factor.
Units	18	US: Gallons per day / PSI, Metric: Liters per day / BAR
Pressure transducer offset	18	00.00 to 99.99. Located on pressure transducer label. Used to calibrate pressure transducer.
Pressure transducer sensitivity	18	00.00 to 99.99. Located on pressure transducer label. Used to calibrate pressure transducer.

Dimensions and Mounting Hole Layout

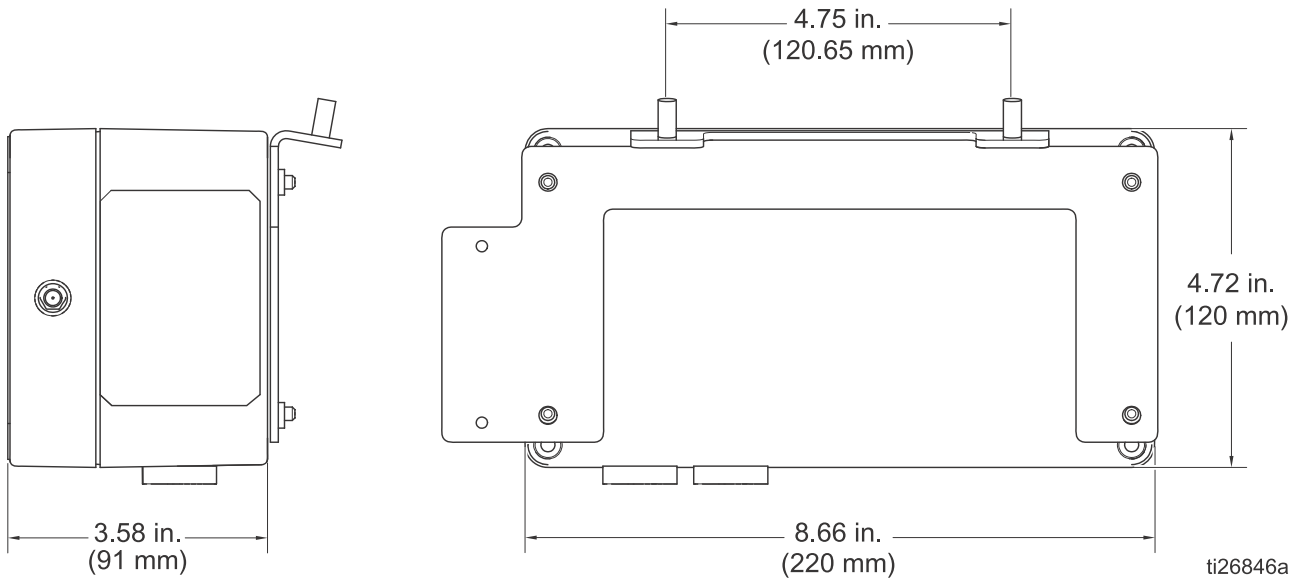

FIG. 39 Harrier+ Dimensions and Mounting Hole Layout

Appendix A: Modbus Interface

PC Interface

If desired, you can connect a PC to your controller by providing an adapter between the PC and the RS232 SCADA Interface cable (see K in FIG. 3 and FIG. 4). Your serial port must be configured as following:

- Comm Port = COM1
- Baud Rate = 115200
- Data Bits = 8
- Parity = None
- Stop Bits = 1
- Flow Control = None

PLC Interface

Gateway adapters to the controller's RS232 SCADA interface (see K in FIG. 3 and FIG. 4) must be provided by user to support other protocols.

Variable Maps

The following tables list Modbus registers available to a PC or PLC.

Table 3: Run Parameters

Modbus Register	Parameter Name	Read / Write	Data Type	Units	Range	Notes
401000	Pressure Psi	Read	uint32	PSI	-1 - 1500 (0 - 0x5DC)	
401002	Battery Milli-volts	Read	uint32	mV	-1 - 50000 (0 - 0xC350)	
401004	Pump Status	Read	uint32	NONE	0 -999 0: = Standby 1: = Run 2: = Lockout Alarm 3: = Lockout Remote	
401006	Cycle Progress	Read	uint32	NONE	0 - 100	
401008	Total	Read	uint32	NONE	0 - 0xFFFFFFFF	
401010	Grand Total	Read	uint32	NONE	0 - 0xFFFFFFFF	

Modbus Register	Parameter Name	Read / Write	Data Type	Units	Range	Notes
401012	Alarm Bit-field	Read	uint32	NONE	0 - 0xFFFFFFFF Bit 0: Software fault Bit 1: Low level Bit 2: Already pressurized Bit 3: Pressure not achieved Bit 4: Over cycle Bit 5: Cycle not detected Bit 6: Count not achieved Bit 7: Input 1 Bit 8: Input 2 Bit 9: Temperature Bit 10: Low Battery Bit 11: Remote Off Bit 12: High pressure Bit 13: Low pressure	
401014	Remote Disable Active	Read	uint32	NONE	0 - 0xFF 0: = FALSE 1: = TRUE	
401016	Pump Status	Write	uint32	NONE	0 - 999 0: = Standby 1: = Run	

Table 4: Setup Parameters

Modbus Register	Parameter Name	Read / Write	Data Type	Units	Range	Notes
401030	Metering Mode	Read	uint32	NONE	0 - 3 0: = Flow 1: = Time 2: Cycles	
401032	On Time	Read	uint32	NONE	0 - 10,000 (0 - 0x2710)	
401034	Off Time	Read	uint32	NONE	0 - 10,000 (0 - 0x2710)	
401036	On Cycles	Read	uint32	NONE	0 - 10,000 (0 - 0x2710)	
401038	On Timeout	Read	uint32	NONE	1 - 10,000 (0 - 0x2710)	
401040	Power Save Mode	Read	uint32	NONE	0 - 4 0: = Power Save Off 1: = Power Save Notify 1: = Power Save Min 2: = Power Save Normal 3: = Power Save Max	
401042	Units	Read	uint32	NONE	0 - 1 0: = Imperial 1: = Metric	
401044	Pressure Offset	Read	uint32	NONE	0 - 0x7FFFFFFF	Returns decimal value*100. i.e.; 0xCCCC returns 80 for 0.8
401046	Pressure Slope	Read	uint32	NONE	0 - 0x7FFFFFFF	Returns decimal value*100. i.e.; 0x230000 returns 3500 for 35
401048	K-Factor	Read	uint32	NONE	1 - 9999	
401050	Desired Flow Rate	Read	uint32	NONE	10 - 25,000	

Modbus Register	Parameter Name	Read / Write	Data Type	Units	Range	Notes
401052	Software Version	Read	uint32	NONE	0 - 0xFFFFFFFF	0x00xyyzz where xx=major, yy = minor, zz = build
401054	High Pressure Trigger	Read	uint32	NONE	0 - 99,999	
401056	Low Pressure Trigger	Read	uint32	NONE	0 - 99,999	
401058	Battery Warning Trigger	Read	uint32	NONE	0 - 99,999	i.e.; Enter 11.8 as 11800
401060	Battery Shut-off Trigger	Read	uint32	NONE	0 - 99,999	i.e.; Enter 11.8 as 11800
401062	Alarm 1 Trigger	Read	uint32	NONE	0 - 2 0: = Disabled 1: = Active High 2: = Active Low	
401064	Alarm 2 Trigger	Read	uint32	NONE	0 - 2 0: = Disabled 1: = Active High 2: = Active Low	
401066	Remote Off Trigger	Read	uint32	NONE	0 - 2 0: = Disabled 1: = Active High 2: = Active Low	
401068	Volume Mode Interval	Read	uint32	NONE	0 - 2 0: = Interval 1 Minute 1: = Interval 5 Minute 2: = Interval 10 Minute	
401070	Metering Mode	Write	uint32	NONE	0 - 3 0: = Flow 1: = Time 2: Cycles	
401072	On Time	Write	uint32	NONE	0 - 10,000 (0 - 0x2710)	
401074	Off Time	Write	uint32	NONE	0 - 10,000 (0 - 0x2710)	
401076	On Cycles	Write	uint32	NONE	0 - 10,000 (0 - 0x2710)	
401078	On Timeout	Write	uint32	NONE	1 - 10,000 (0 - 0x2710)	
401080	Power Save Mode	Write	uint32	NONE	0 - 4 0: = Power Save Off 1: = Power Save Notify 1: = Power Save Min 2: = Power Save Normal 3: = Power Save Max	
401082	Units	Write	uint32	NONE	0 - 1 0: = Imperial 1: = Metric	
401084	Pressure Offset	Write	uint32	NONE	0 - 0x7FFFFFFF	Returns default value when out of range.
401086	Pressure Slope	Write	uint32	NONE	0 - 0x7FFFFFFF	Returns default value when out of range.

Modbus Register	Parameter Name	Read / Write	Data Type	Units	Range	Notes
401088	K-Factor	Write	uint32	NONE	1 - 9999	
401090	Desired Flow Rate	Write	uint32	NONE	10 - 25,000	Returns max allowed value when too large for Kfactor setting.
401092	High Pressure Trigger	Write	uint32	NONE	0 - 99,999	
401094	Low Pressure Trigger	Write	uint32	NONE	0 - 99,999	
401096	Battery Warning Trigger	Write	uint32	NONE	0 - 99,999	i.e.; Enter 11.8 as 11800
401098	Battery Shut-off Trigger	Write	uint32	NONE	0 - 99,999	i.e.; Enter 11.8 as 11800
401100	Alarm 1 Trigger	Write	uint32	NONE	0 - 2 0: = Disabled 1: = Active High 2: = Active Low	
401102	Alarm 2 Trigger	Write	uint32	NONE	0 - 2 0: = Disabled 1: = Active High 2: = Active Low	
401104	Remote Off Trigger	Write	uint32	NONE	0 - 2 0: = Disabled 1: = Active High 2: = Active Low	
401106	Volume Mode Interval	Write	uint32	NONE	0 - 2 0: = Interval 1 Minute 1: = Interval 5 Minute 2: = Interval 10 Minute	

Table 5: Reset Parameters

Modbus Register	Parameter Name	Read / Write	Data Type	Units	Range	Notes
401120	Reset Totalizer	Write	uint32	NONE	0 - 1 0: = FALSE 1: = TRUE	Must write 1 to reset totalizer.
401122	Clear Alarm Status	Write	uint32	NONE	0 - 1 0: = FALSE 1: = TRUE	Must write 1 to clear alarms.

Technical Data

Input Contact	
Power Source (DC) - models B32022, B32148, B32155	9 - 26 VDC
Power Source (AC) - models B32189, B32150, B32156	100 VAC to 240 VAC - 50/60 Hz
Power consumption, max load (DC)	416 Watts
Power consumption, max load (120 VAC)	360 Watts
Power consumption, max load (240 VAC)	720 Watts
Cycle Control Pressure Input	Normally open cycle switch
Remote Disable (Auxiliary) Input	Configurable active high/low for normally open or normally closed switch
Outputs	
Pump control	Pump Control Voltage = Power Source
Voltage	Power Source
Max Switching Voltage (DC)	26 VDC
Max Switching Voltage (AC)	240 VAC
Max Switching Current (DC)	16 A
Max Switching Current (AC)	3 A
Minimum Switching Capacity	100 mA @ 5 VDC
Enclosure Material	Aluminum
Membrane Material	Polyester
Bushing Material	Nylon 6/6 and TPE
Environmental	
Protection Grade	IP54 for indoors
Operating Temperature Range	- 40°F to 131°F (- 40°C to 55°C)
Storage Temperature	- 13°F to 131°F (- 25°C to 55°C)

Graco Standard Warranty

Graco warrants all equipment referenced in this document which is manufactured by Graco and bearing its name to be free from defects in material and workmanship on the date of sale to the original purchaser for use. With the exception of any special, extended, or limited warranty published by Graco, Graco will, for a period of twelve months from the date of sale, repair or replace any part of the equipment determined by Graco to be defective. This warranty applies only when the equipment is installed, operated and maintained in accordance with Graco's written recommendations.

This warranty does not cover, and Graco shall not be liable for general wear and tear, or any malfunction, damage or wear caused by faulty installation, misapplication, abrasion, corrosion, inadequate or improper maintenance, negligence, accident, tampering, or substitution of non-Graco component parts. Nor shall Graco be liable for malfunction, damage or wear caused by the incompatibility of Graco equipment with structures, accessories, equipment or materials not supplied by Graco, or the improper design, manufacture, installation, operation or maintenance of structures, accessories, equipment or materials not supplied by Graco.

This warranty is conditioned upon the prepaid return of the equipment claimed to be defective to an authorized Graco distributor for verification of the claimed defect. If the claimed defect is verified, Graco will repair or replace free of charge any defective parts. The equipment will be returned to the original purchaser transportation prepaid. If inspection of the equipment does not disclose any defect in material or workmanship, repairs will be made at a reasonable charge, which charges may include the costs of parts, labor, and transportation.

THIS WARRANTY IS EXCLUSIVE, AND IS IN LIEU OF ANY OTHER WARRANTIES, EXPRESS OR IMPLIED, INCLUDING BUT NOT LIMITED TO WARRANTY OF MERCHANTABILITY OR WARRANTY OF FITNESS FOR A PARTICULAR PURPOSE.

Graco's sole obligation and buyer's sole remedy for any breach of warranty shall be as set forth above. The buyer agrees that no other remedy (including, but not limited to, incidental or consequential damages for lost profits, lost sales, injury to person or property, or any other incidental or consequential loss) shall be available. Any action for breach of warranty must be brought within two (2) years of the date of sale.

GRACO MAKES NO WARRANTY, AND DISCLAIMS ALL IMPLIED WARRANTIES OF MERCHANTABILITY AND FITNESS FOR A PARTICULAR PURPOSE, IN CONNECTION WITH ACCESSORIES, EQUIPMENT, MATERIALS OR COMPONENTS SOLD BUT NOT MANUFACTURED BY GRACO. These items sold, but not manufactured by Graco (such as electric motors, switches, hose, etc.), are subject to the warranty, if any, of their manufacturer. Graco will provide purchaser with reasonable assistance in making any claim for breach of these warranties.

In no event will Graco be liable for indirect, incidental, special or consequential damages resulting from Graco supplying equipment hereunder, or the furnishing, performance, or use of any products or other goods sold hereto, whether due to a breach of contract, breach of warranty, the negligence of Graco, or otherwise.

FOR GRACO CANADA CUSTOMERS

The Parties acknowledge that they have required that the present document, as well as all documents, notices and legal proceedings entered into, given or instituted pursuant hereto or relating directly or indirectly hereto, be drawn up in English. Les parties reconnaissent avoir convenu que la rédaction du présente document sera en Anglais, ainsi que tous documents, avis et procédures judiciaires exécutés, donnés ou intentés, à la suite de ou en rapport, directement ou indirectement, avec les procédures concernées.

Graco Information

For the latest information about Graco products, visit www.graco.com.

For patent information, see www.graco.com/patents.

TO PLACE AN ORDER, contact your Graco distributor or call to identify the nearest distributor.
Phone: 612-623-6928 or **Toll Free:** 1-800-533-9655, **Fax:** 612-378-3590

*All written and visual data contained in this document reflects the latest product information available at the time of publication.
Graco reserves the right to make changes at any time without notice.*

Original instructions. This manual contains English. MM 3A3098

Graco Headquarters: Minneapolis

International Offices: Belgium, China, Japan, Korea

GRACO INC. AND SUBSIDIARIES • P.O. BOX 1441 • MINNEAPOLIS MN 55440-1441 • USA
Copyright 2015, Graco Inc. All Graco manufacturing locations are registered to ISO 9001.

www.graco.com

Revision B, September 2015